

LINKWITZ LAB

Design & Consultation in Electronics & Acoustics

ORION Construction Kit Documentation

Revision 1/19/06

TABLE OF CONTENTS

1. Introduction	2
2. Cabinet Construction	3
2.1 Wood parts list	6
2.2 Baffle drawing	7
2.3 Side panel drawing	8
2.4 Cover panel drawing	9
3. Driver Mounting and Hook-up	10
3.1 Driver polarity test	11
3.2 Material list	12
4. Crossover/Equalizer Circuit	13
4.1 ASP block diagram	15
4.2 Circuit diagram	16
5. Circuit Board Assembly	18
5.1 Material list & loading table	19
5.2 Component designations	22
6. Circuit Board Interconnections	23
6.1 Circuit side drawing	24
7. Circuit Test	25
7.1 Transfer function graph	27
7.2 Test table	28
8. System Turn-on	29
8.1 Pink noise tests	29
8.2 Rattle and buzz test	30
8.3 System hook-up	31

For updates and support see:

www.linkwitzlab.com/orion-support.htm

This documentation is copyrighted and for the personal, non-commercial use by the person who bought it from LINKWITZ LAB. It may not be passed on in any form for use by others.

LINKWITZ LAB - 15 Prospect Lane - Corte Madera - CA 94925 - USA

Phone +1 415 924 0241 - Fax +1 415 924 6592 -

E-mail sl@linkwitzlab.com - Web www.linkwitzlab.com

1. Introduction

Congratulations on your decision to build the ORION. When completed you will have a loudspeaker system that gives you the most direct access to the soul of sound. I am certain that this speaker can provide you with years of enjoyment.

The design of the ORION culminates for me some thirty years of work on loudspeakers and learning about the requirements for accurate sound reproduction in domestic living spaces. In the ORION I have integrated desirable visual features with necessary acoustic shapes. Each detail of the speaker has its purpose and must not be changed. With color, wood finish and grill cloth you may safely express your creativity and personal preference. This speaker could not have been built before, because drivers of this quality were not available, nor did I know that the phase distortion of a 24 dB/octave crossover at 120 Hz was inaudible.

The performance of the ORION proves that many of the common audiophile tenets for high-end speakers do not apply to this open baffle design. Tenets like, the midrange driver should be smaller, the tweeter should be a ribbon, the tweeter is mounted too high, the baffle is too wide, the cabinet is not massive enough, the cabinet vibration causes Doppler distortion, dipoles cannot reproduce deep bass, the crossover has too many components, the crossover uses operational amplifiers, LR4 crossovers have too much time smear, the transient response is distorted, speaker placement is critical, the rear radiation must be absorbed, the sweet spot for best imaging is tiny, the speakers are too small for creating a large sound stage, and so on. Yes, the speakers will vibrate at the top, as you can easily feel on heavy bass material, but it has no audible consequences. If you hold some of the above beliefs, I can only suggest to relax, sit back and listen. Allow yourself to be drawn into the music and rest assured that I have investigated quite thoroughly the mentioned concerns and more. The ORION is not an accident. Little about it is arbitrary, so do not change its design, thinking that you will improve on it.

Music and its reproduction has been a life long passion for me, which I pursued outside of my career in R&D of electronic test equipment. I am very pleased with the ORION and I would like to share my enjoyment with others. That is why I offer this Construction Kit. It can be a difficult project to undertake, depending on your previous experience with wood working and electronics. That is why I offer the finished Crossover/Equalizer or the option to have us test and repair, if necessary, your fully assembled Crossover/Equalizer. But if you follow instructions carefully and keep your creativity at bay, you will surely succeed.

Enjoy the construction process and then the results!

Siegfried Linkwitz

2. Cabinet Construction

- 2.1 Wood parts list
- 2.2 Baffle drawing
- 2.3 Side panel drawing
- 2.4 Cover panel drawing

The cabinet construction is kept as simple as possible. Each part has some mechanical or acoustical functionality and its dimensions should not be changed. Only butt joints are used. More complicated joinery may satisfy your woodworking sensibilities, but will not improve the sound. The cabinet has two subassemblies, the woofer frame and the midrange baffle. The side panels are attached last.

My construction technique consists of clamping parts together, pre-drilling and countersinking for 1-1/4 dry wall screws. The clamps are removed, glue (e.g. Elmer's Carpenter's Wood Glue) is applied to the wood ends and the parts are screwed together. Any excess glue is removed immediately.

See the parts list and three drawings for reference.

Midrange Baffle

Cut part A out of 1/2 inch plywood and cut out the driver mounting holes using a saber saw or router. Check that the drivers seat into the openings. Join A with parts C and D using glue and screws.

Cut the dress panel B with its holes out of 1/4 inch plywood. Use the same veneer as for the side panels, if you want to have the same wood finish. The dress panel is smaller size than A to leave a 1/4 inch setback at the top and 1/2 inch at the sides to create strong visual shadow lines. Check that the dress panel clears the driver outsides. Do not attach B at this time.

Woofer Frame

Cut out all the pieces out of 3/4 inch plywood or MDF and the woofer mounting holes in E. Check that the woofers can be properly seated in the holes.

Join top F with left and right parts H. Add part C.

Join bottom F with left and right parts J.

Join the two subassemblies to woofer panel E.

Add left and right parts I and then G.

Internal Frame

Join the midrange baffle to the woofer frame.

Drill two 1/2 inch wiring holes WH for routing the speaker wires later.

Fill any screw holes that might be visible later with wood putty.

Paint the whole frame in flat black color.

Side Panels

Draw up a template for the side panels K on 1/8 inch hardboard (Masonite). All the curves are sections of circles. Cut out the template with a saber saw. Sand the edges for a visually smooth flow in curvature.

Use the template to outline the side panels on 3/4 inch plywood or MDF. Flip the template over to use the good side of the plywood for left and right sides. Cut out the side panels with a saber saw or a router.

Varnish and lacquer finish the side panels K or paint them. Glue veneer tape to the panel edges if desired. Use the same finish for the dress panel B.

Final cabinet assembly

Before you glue the finished dress panel to the painted midrange baffle confirm that midrange and tweeter will mount concentric in the panel holes. Mark the mounting screw holes for the drivers and pre-drill them.

Glue the finished dress panel to the painted midrange baffle using 3M, Scotch Brand, adhesive transfer tape 468MP or contact cement. A 60 yard roll of 1 inch wide tape costs \$14 and is available from Michelle Nunes, mnunes@woodartistry.com at www.woodartistry.com. Cover the whole rear of the dress panel with strips of tape. The goal is to create an elastic damping layer. If the midrange driver is mounted by the magnet as in Revision 0.1, then the dress panel can be hard glued, or dress panel and midrange baffle could be made out of one piece with the details routed.

Lay the first side panel horizontal on a clean surface and the internal frame on top of it. Align side panel and frame so that their bottoms coincide. The front edge of the side panel at the top should be flush with the surface of the dress panel. This forms a 1/4" deep groove to the side of the dress panel for cosmetic and acoustic reasons. The front bottom corner of the side panel is 1/2 inch forward of the frame bottom corner.

Clamp the two pieces in place.

Run 1-1/4 inch dry wall screws from the frame into the side panel. Pre-drill and counter sink the holes. No glue is used to hold the side panels, but do not skimp on the screws.

Repeat the procedure for the other side panel.

Cover the new screws and holes with black paint.

Cover Panels

In addition to the dress panel there are 3 grill frames. An easily removable dress cover to hide the midrange and tweeter and a front and a rear grill cover for the woofer. The frames are cut out of 1/8 inch hardboard (Masonite) panels. The narrow width of the front panels allows for a 1/2 inch shadow line. The panels are painted black on the side facing the grill cloth to mask the baffle background.

Grill cloth can usually be found at local fabric stores, at least in black. A great variety of colors is available from ACOUSTEX, <http://www.acoustex.com/colorcardset.htm>, phone 781-229-2100.

The fabrics are 66 inch wide and the price is around \$29/yard. I like their #78 Toffee.

The cloth should be cut 1 inch wider on each side than the panels to allow for wrapping around the edges and gluing to the backside.

For instant but removable attachment I use 3M, Scotch Brand, adhesive transfer tape 468MP. A

ORION Construction Kit

60 yard roll of 1 inch wide tape costs \$14. <http://www.woodartistry.com/Audio.htm> . The cloth should be stretched on the frames. The rounded contours require special attention to avoid wrinkles. Make cuts at 2 inch intervals into the overhang of the cloth.

Front and rear grill covers are attached with black, self-adhesive hook-and-loop (Velcro) strips at top, middle and bottom of the internal frame. (Radio Shack 64-2345)

2.1 Wood parts for 2 ORION speaker cabinets

1 - Top baffle for midrange and tweeter

Part	Qty	Size (inch)	Material	Use
A	2	11.5 x 21.5 x 1/2	Plywood	Midrange & tweeter baffle with 2 holes
B	2	10.5 x 18.25 x 1/4	Birch Plywood	Dress panel with 2 holes
C	2	11.5 x 3.5 x 3/4	Plywood	Brace for mounting to woofer
D	4	20 x 3/4 x 3/4	Hardwood	Corner brace for side panel mounting

24 x 24 x 1/2 sheet of multi-ply

24 x 24 x 1/4 sheet of birch plywood

84 x 3/4 x 3/4 oak

2 - H-frame for woofer

Part	Qty	Size	Material	Use
E	2	11.5 x 23 x 3/4	Plywood or MDF	Woofer baffle with 2 holes
F	4	11.5 x 11.5 x 3/4	Plywood or MDF	Top & bottom cover
C	2	11.5 x 3.5 x 3/4	Plywood or MDF	Brace
G	2	11.5 x 2 x 3/4	Plywood or MDF	Brace
H	4	12 x 6.25 x 3/4	Plywood or MDF	Top side cover
I	4	12 x 4.5 x 3/4	Plywood or MDF	Bottom side cover
J	4	6.25 x 2 x 3/4	Plywood or MDF	Side panel mounting

48 x 48 x 3/4 sheet

3 - Side panels

Part	Qty	Size	Material	Use
K	2 + 2	46-3/8 x 16 x 3/4	Birch plywood (8 ply)	Wood finished side panels, L & R
			Plywood or MDF	Painted side panels, L & R
	1	46-3/8 x 16 x 1/8	Hardboard, Masonite	Template

48 x 48 x 3/4 sheet

48 x 24 x 1/8 sheet

4 - Dress and grill covers

Part	Qty	Size	Material	Use
L	2	10.5 x 20.0 x 1/8	Hardboard	Dress cover
M	2	10.5 x 1.0 x 1/2	Plywood	Cover support
N	2	10.5 x 1.0 x 1/8	Hardboard, Masonite	Cover retainer
O	2	10.5 x 27.5 x 1/8	Hardboard, Masonite	Front woofer grill with 2 cutouts
P	2	11.0 x 22.5 x 1/8	Hardboard, Masonite	Rear woofer grill with 2 cutouts

48 x 48 x 1/8 sheet

Total: 16 different parts, 47 pieces

ORION baffle

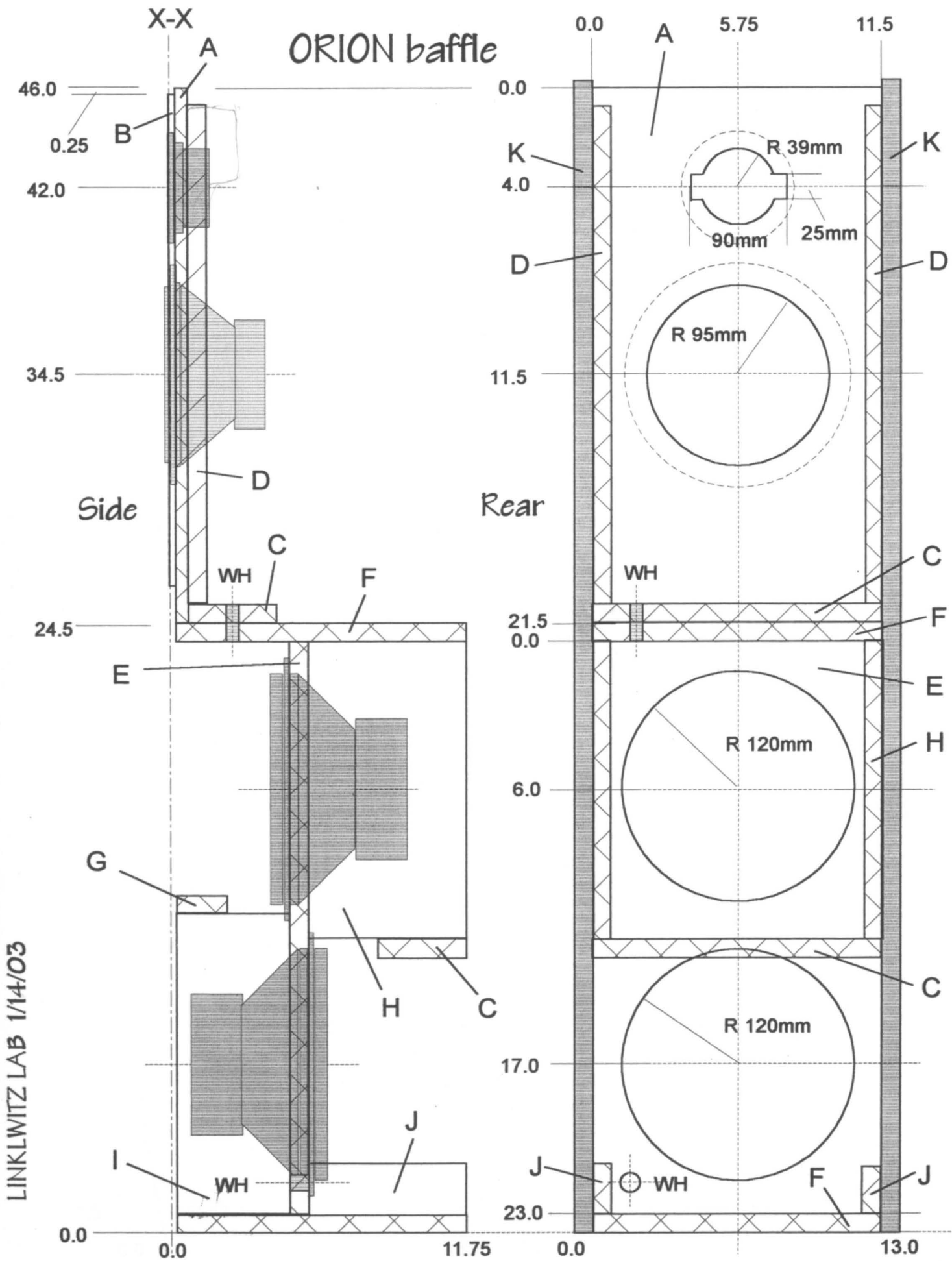

LINKLWITZ LAB 1/14/03

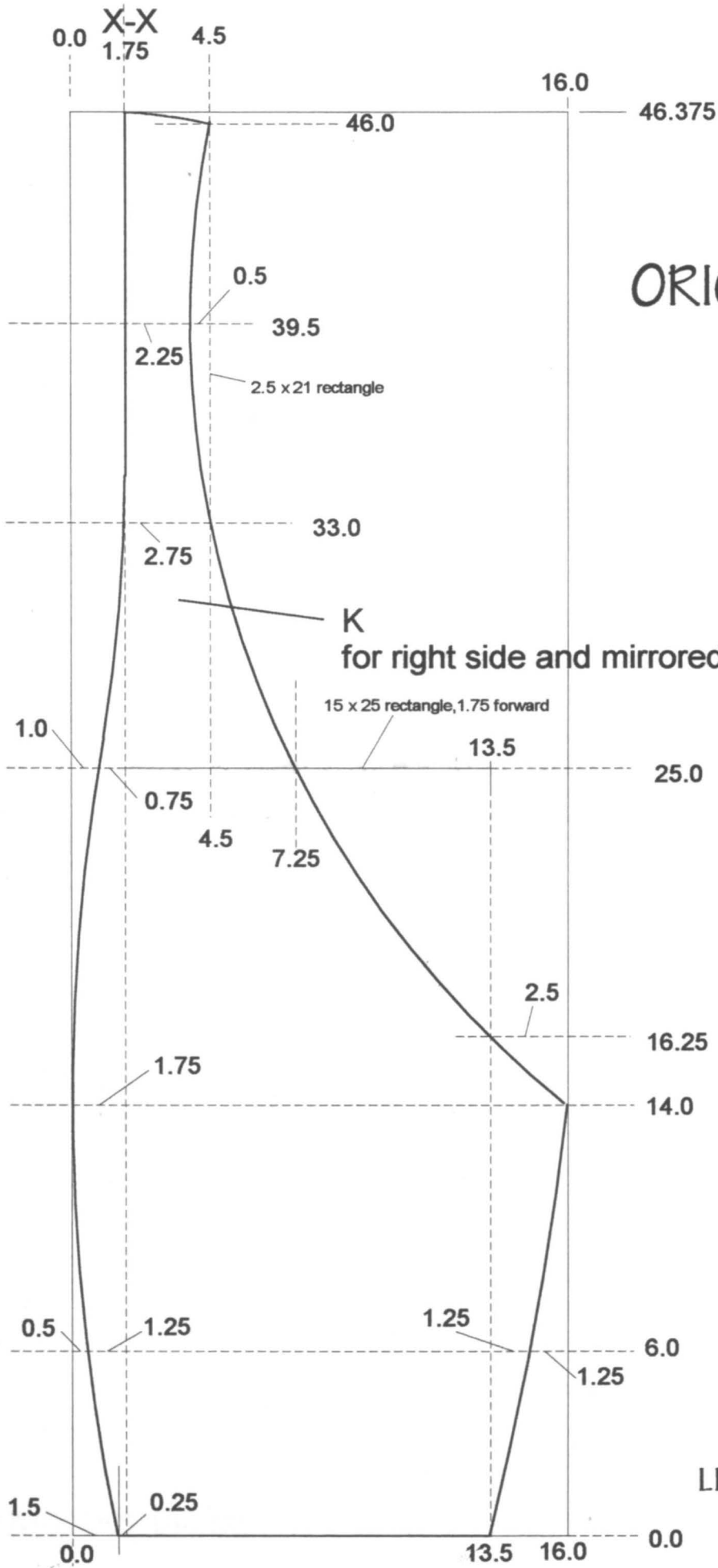

ORION side panel

LINKWITZ LAB 1/14/03

ORION cover panels

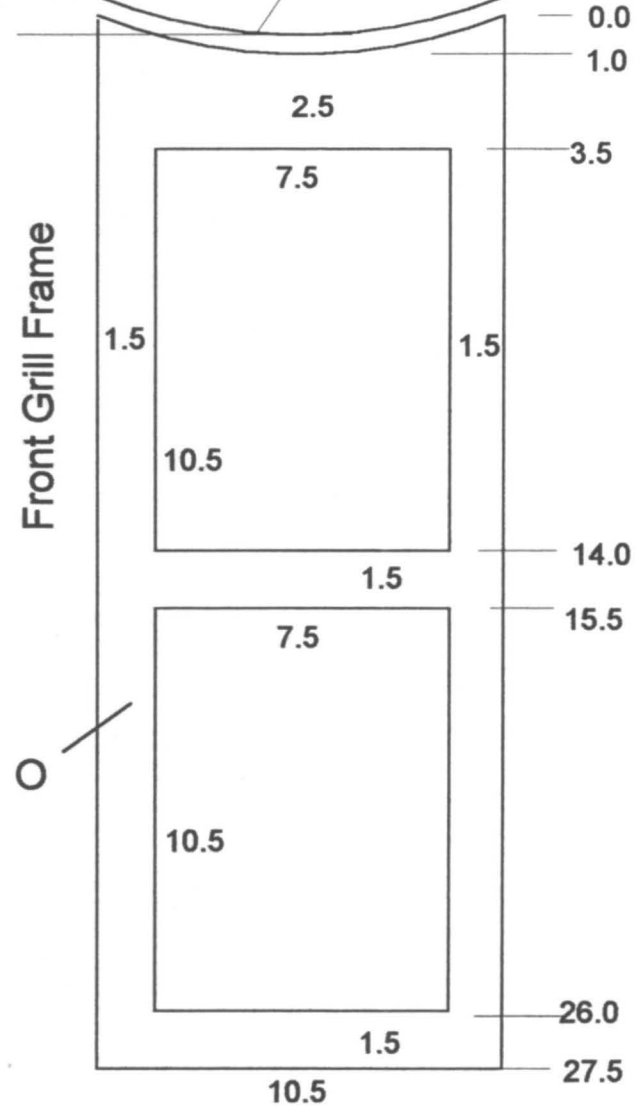
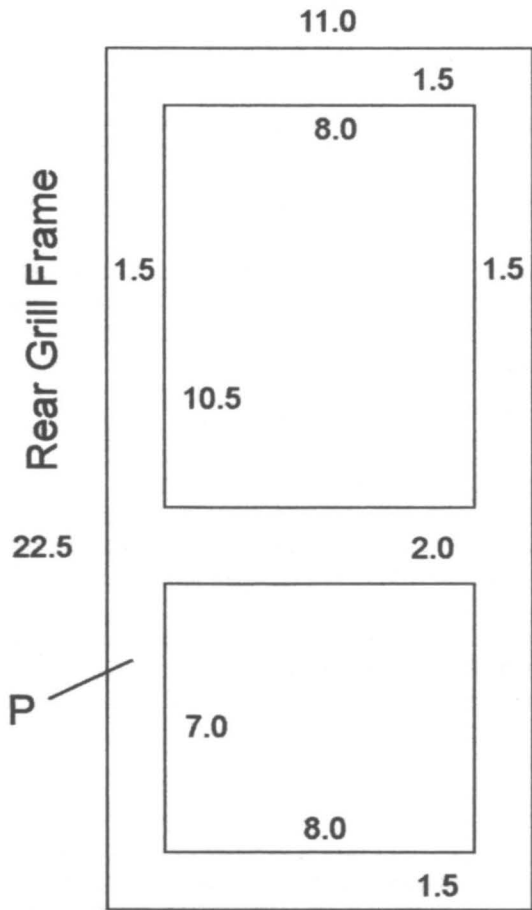
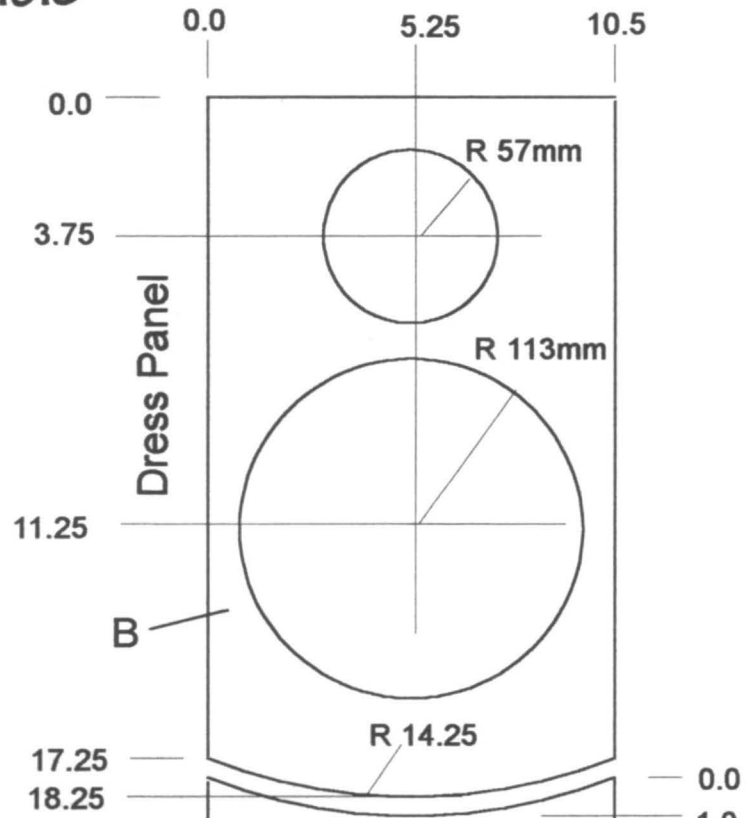
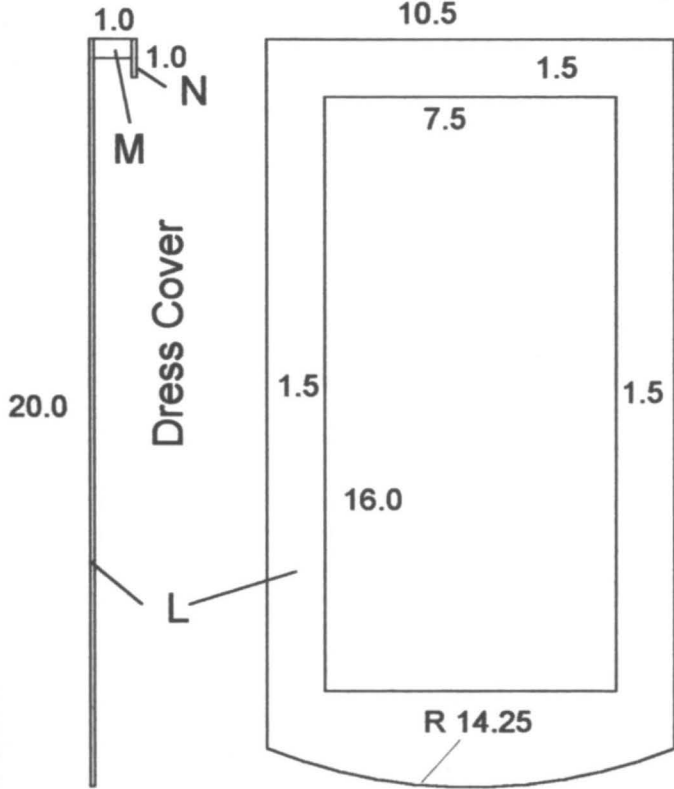

3. Driver Mounting and Hook-up

The drivers are mounted after the cabinets have been completely finished so there is no danger of damaging them mechanically.

Before the drivers are screwed into the cabinet they should have their wiring attached unless you plan to use slip-on lugs on the driver terminals. I prefer solder joints. Strip and pre-tin all ends before soldering. Be extremely careful with midrange and woofer drivers not to drip solder onto the exposed voice coil! Use 16 gauge 2-conductor speaker wire (e.g. Radio Shack part #278-1267).

Tweeter 60 inch

Midrange 50 inch

Top woofer 30 inch

Bottom woofer 15 inch

Seat the drivers into their cutouts with the cabinets laid horizontal. Mark the mounting screw holes and pre-drill them.

Attach strips of PVC closed cell soft foam weather-strip tape (1/4 in thick x 3/8 in wide) to the hole perimeters, so that the drivers are not mounted directly against a hard surface. The frames of midrange and tweeter should be approximately flush with the dress panel surface when screwed down. Use 6x5/8 inch long black oxide plated square drive pan head screws. The woofers are screwed down with 6x1 inch screws. (e.g. McFeely's 1-800-443-7937, part #0605-TRK and 0610-TRK)

After the drivers have been inserted and screwed down wait for a day and then check tightness of the mounting screws. The weather strip foam tape will have taken a set. This is desirable. You should not use a hard rubber gasket material that remains springy. It might cause buzzing distortion when the driver frame hits the mounting screws.

The material should be pliable. For example, a Frost King vinyl foam weather seal V212G (charcoal) or V443 (gray) works well. It is 3/16" thick x 3/8" wide.

The wires coming from the tweeter and midrange drivers are routed through 2 holes, the lower woofer through one hole to end up at the bottom rear of the cabinet together with the wires from the upper woofer. All wires are soldered to terminal strips to provide 4 pairs of terminals, T, M, W1 and W2, to which the speaker cables will be soldered. Do not worry about driver polarity up to this point. Attach the speaker wires to the cabinet with hot glue so that they cannot vibrate against the wood and rattle.

Speaker cables are usually connected with binding posts, but soldered junctions are preferable for greater reliability over time. For the speaker cables use 16 gauge copper 2-conductor wire if the length is under 12 feet. Use 14 gauge up to 20 feet. Each speaker requires 4 cables. Measure and cut them to the length needed for your installation.

Strip, pre-tin and then solder the cables to the terminal strips at the speaker bottom. Run the 4 cables through a cable clamp screwed to the bottom for strain relief. The rear grill cover gives clearance for the cable to exit from the bottom of the speaker.

Fiber braided sleeve can be used to make a neat wrap around the four speaker cables. Shrink tubing can then be added to terminate the end of the wrap, and leave about one foot of individual cable end exposed at the amplifier end. White colored shrink tubing can then be added to the exposed ends and marked with as black pen as T, M, W1, W2.

Each speaker cable is terminated with 4 dual banana plugs (e.g. Radio Shack #274-717) at the power amplifier end. Designate the tab on the connector side to indicate the (-) polarity plug. The drivers must be connected in the correct polarity to the power amplifier, which means that midrange and tweeter cones move forward and the two woofer cones move forward, when a positive voltage is applied to the (+) plug on the connector. This must be tested.

3.1 Driver polarity test

Solder short wires to the (+) and (-) sides of a D-cell battery. Start with a woofer driver. Temporarily attach the two battery wires to the two speaker cable wires. Find out which lead of the speaker cable makes the cone move towards the front of the cabinet when connected to (+) of the battery. This lead must be screwed into the (+) side of the dual banana plug. The other lead goes to the (-) side of the plug. Repeat this process for the other woofer. Note that one cone moves towards the magnet while the other moves away from it when the (+) of the battery is connected to the (+) of each woofer banana plug. Both cones must move towards the front of the cabinet for proper polarity.

Similarly check that the midrange cone moves forward when battery (+) is touching the connector (+). The tweeter dome must move forward when its (+) cable plug side touches the battery (+) side. The dome displacement is small, but clearly observable from the side.

The correct driver polarity is most important for proper behavior of the speaker. All cones must move in the same absolute direction when connected to (+) of the battery.

3.2 Drivers, wiring and mounting material

LINKWITZ LAB 9/26/02

M = www.madisound.com
 R = Radio Shack
 F = McFeely's 1-800-443-7937

Order Qty	Used Qty	Value/size	Attributes	Mfct-Series	Part No.	\$ each	Order \$ total
2	2	25 mm	Tweeter	Seas Excel - Millennium	M T25CF002	\$149.00	\$298.00
2	2	22 cm	Midrange	Seas Excel	M W22EX001	\$162.80	\$325.60
4	4	10 inch	Woofers	Peerless XLS	M 830452	\$127.50	\$510.00
8	8		Dual in-line banana plug		R 274-717	\$2.99	\$23.92
1	4		Solder-type terminal strips, 5 lugs		R 274-688	\$1.29	\$1.29
1	8		Insulated wire staples		R 64-2875	\$1.49	\$1.49
2	2	16 gauge	2-conductor speaker wire, 50 feet		R 278-1267	\$8.99	\$17.98
0	2	16 gauge	2-conductor speaker wire, 50 feet		R 278-1270	\$16.99	\$0.00
1	1	1/4 x 3/8 in	Weatherstrip tape, 20 feet			\$2.00	\$2.00
1	20	6 x 5/8 in	Black square drive screws, 100	McFeely's	F 0605-TRK	\$3.07	\$3.07
1	32	6 x 1 in	Black square drive screws, 100	McFeely's	F 0610-TRK	\$3.31	\$3.31
							\$1,180.28

12

4. Crossover/Equalizer circuit description

4.1 Block diagram of the Analog Signal Processor

4.2 Circuit diagrams (2)

A 140 kHz low-pass filter is at the input to the Crossover/Equalizer to block radio frequency signals from interfering.

The U1A stage forms a shelving high-pass filter to aid the frequency response transition from woofer to midrange. The woofer rests on a large plane and radiates into 2π space, the midrange essentially into 4π .

A 50 Hz "Low-cut" high-pass filter can be switched into the signal path, by opening S1, to reduce woofer cone excursions at very low frequencies. The output of the filter is buffered against loading by U1B, which also provides low impedance drive for the woofer and midrange/tweeter channels.

U2A and U2B stages form the 24 dB/oct high-pass filter section of the 120 crossover between woofer and midrange.

U3A and U3B are phase shifting all-pass networks, which delay the midrange and tweeter signals. They correct for the physical offset between the acoustic centers of woofer and midrange.

U4B and U7A stages form the 24 dB/oct low-pass filter section of the 1440 Hz crossover between midrange and tweeter.

U7B in conjunction with R49 forms a 5 kHz notch filter to correct for a midrange driver out-of-band resonance.

U8A equalize the dipole roll-off of the midrange.

The U8B stage in conjunction with R49 gives a shallow notch in the midrange drive signal response. This is a highly critical stage for correct sound. R307 and C62 allow for trimming.

U4A and U5B stages form the 24 dB/oct high-pass filter section of the midrange to tweeter crossover.

U6A provides ± 2.5 dB tweeter gain adjustment range to compensate for any sensitivity variation of the tweeter driver relative to the midrange driver, which can be in the order of ± 0.5 dB. The adjustment can also be set to allow for room differences and for subjective preferences, but could degrade electro-acoustic accuracy.

U6B and U5A form phase shifting all-pass networks to correct for the physical offset between midrange and tweeter.

U9A and U11A stages form the 24 dB/oct low-pass filter section of the 120 Hz crossover between midrange and woofer.

U9B provides ± 2.5 dB woofer gain adjustment range to compensate for any sensitivity variation of the woofer driver relative to the midrange driver, which can be in the order of ± 0.5 dB. The adjustment can also be set to allow for room differences and for subjective preferences, but could degrade electro-acoustic accuracy.

The shelving low-pass filter around U11B compensates for the driver roll-off due to low Qts. It also gives the first of two 20 Hz poles.

The U10B stages compensates the dipole roll-off of the woofer and sets the second 20 Hz pole. The two poles at 20 Hz form a 2nd order high-pass filter with $Q = 0.5$ for best transient response and no group delay peak.

The U10A stage is not used, but could provide a notch filter in conjunction with R70 to reduce a strong room resonance mode.

ORION Construction Kit

The 2 Hz high-pass filter blocks any dc offset voltage from reaching the power amplifier, in case the amplifier is dc-coupled at its input.

Components in the circuit diagram that do not have a value assigned to them are not used for the ORION.

At the output of each stage are test points TP1 to TP18 for trouble shooting the circuit.

ORION ASP Block diagram

LINKWITZ LAB 1/26/04

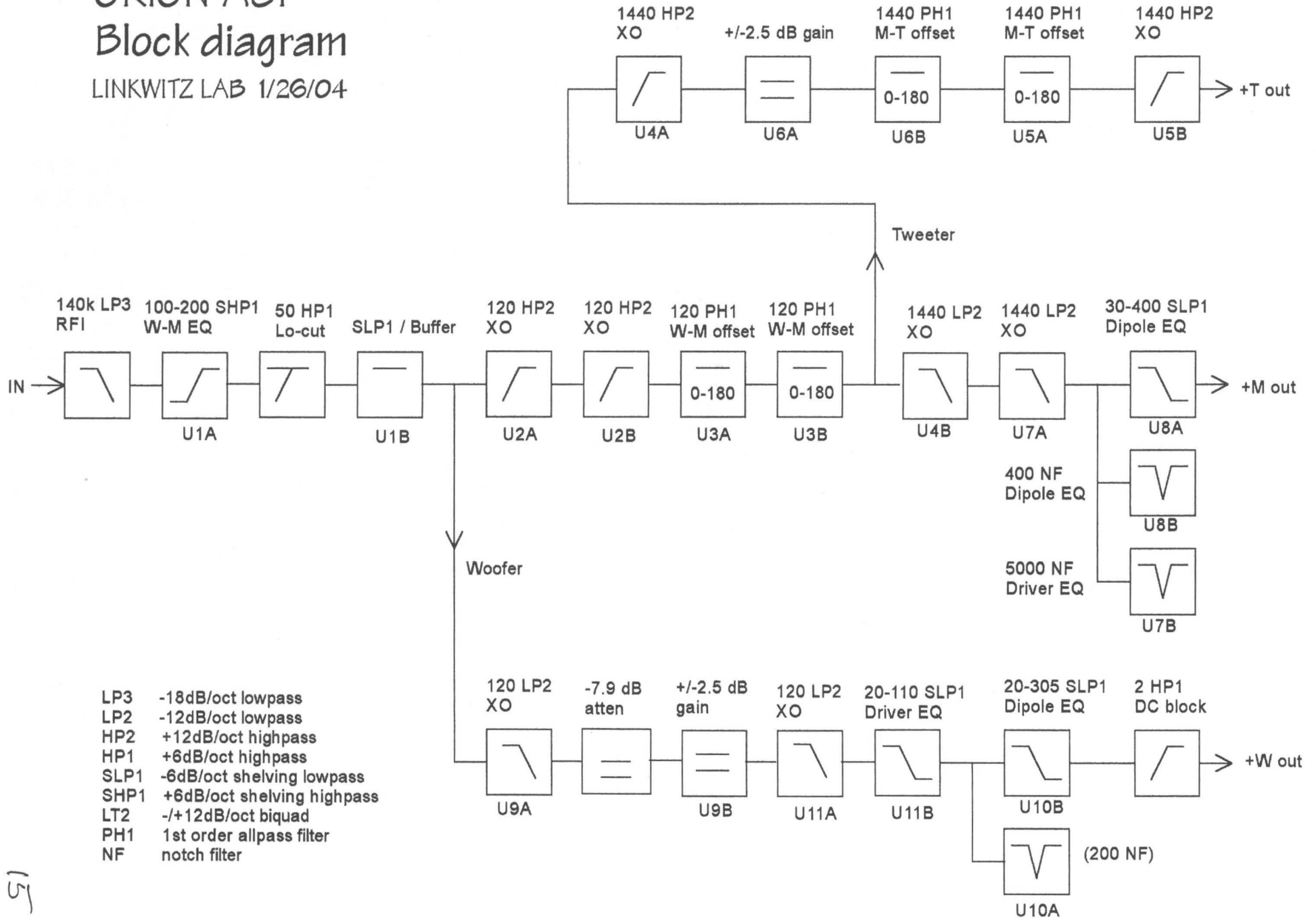

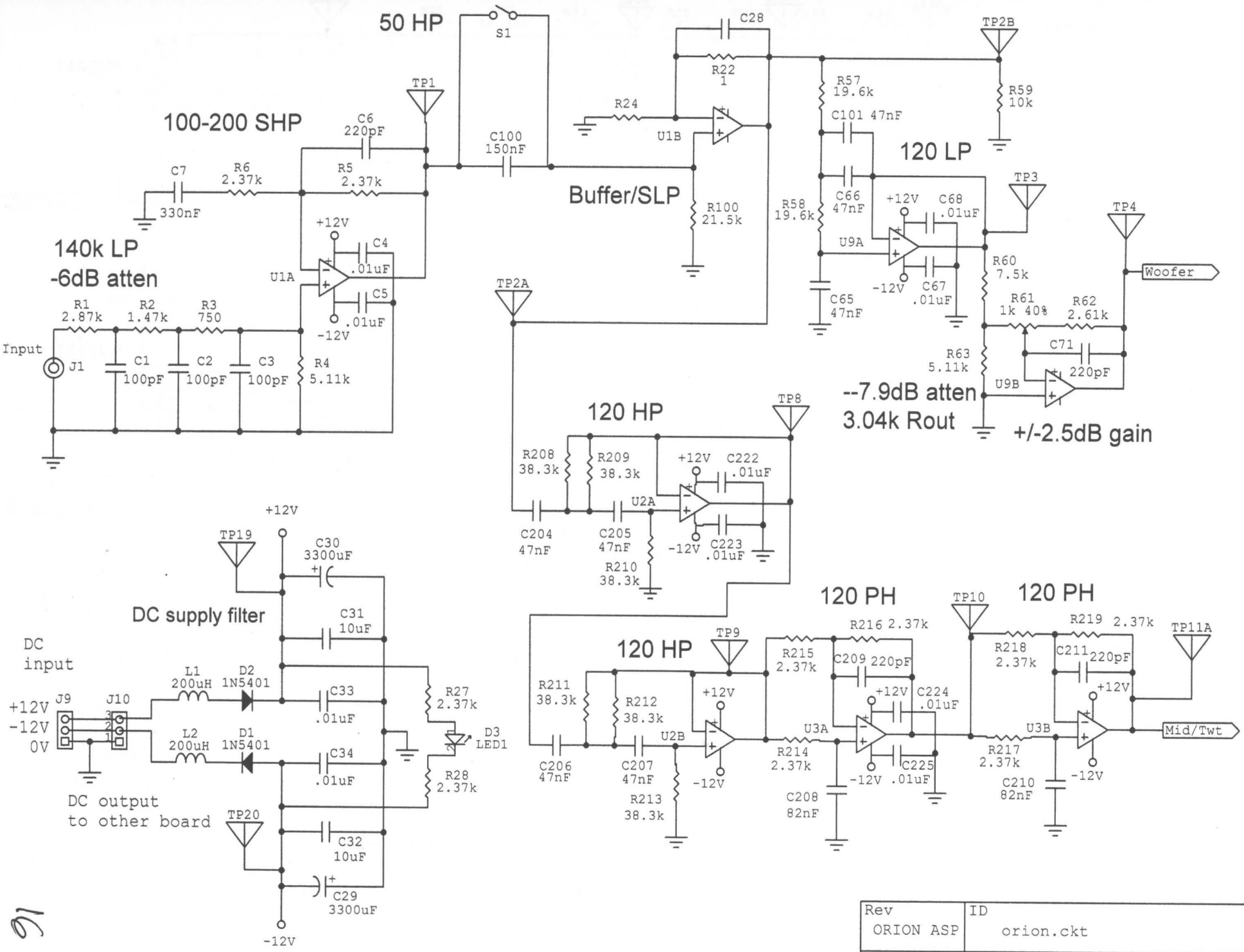

Rev	ID
ORION ASP	orion.ckt
Date: 22 March, 2007	Page: 1 of 2

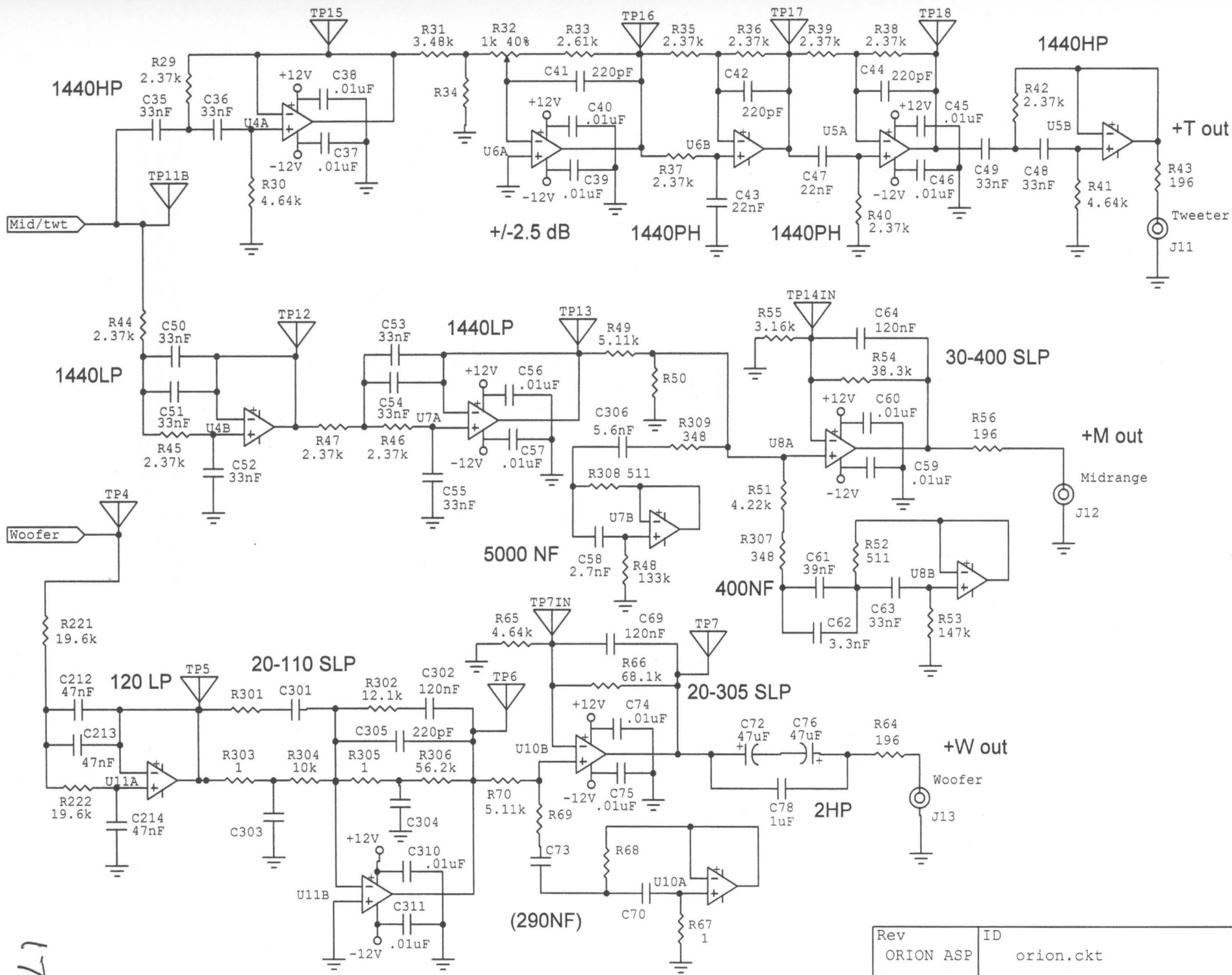

L7

Rev	ID
ORION ASP	orion.ckt
Date: 22 March, 2007	Page: 2 of 2

5. Circuit Board Assembly

5.1 Material list and loading table

The Kit uses two ORION circuit boards, one for each channel, to drive tweeter, midrange and woofer power amplifiers. Follow the material list to order the necessary parts. Use the right hand column of the material list as your loading table to find the designation on the circuit board for placing and soldering the component.

Use a 30 Watt soldering iron and rosin-core solder of 0.032 inch diameter. An iron holder and tip cleaner combination provides for safe storage of the hot soldering iron and clean solder joints. Use insulated 22 gauge solid hookup wire for the interconnections between boards. These items are available at Radio Shack.

Load and solder the needed IC sockets first. Follow the loading table or the circuit schematic. Insert the sockets to match the orientation of the silk screen. Hold the sockets in place with masking tape so that they do not fall out when the boards are turned over for soldering.

Bend the resistor leads according to the hole spacing and insert them in the locations defined by Rxy. Bend the leads of the resistors outwards on the circuit side of the pcb to keep them from falling out when you turn over the board. Solder the resistors and clip off the excess leads after about 10 resistors have been inserted. Continue until all resistors are loaded.

You might want to build yourself a lead bending tool out of a V-shaped strip of 1/8" Masonite that is 1" wide on one end and tapers to 1/4" on the other end. Put notches in the sides to get 0.5" spacing for bending the resistor leads. Make notches at wider and narrower spacing for the other components according to their hole spacing on the pcb..

The normal mode for operating and testing the board is with S1 closed. If you do not plan on using the low frequency cut switch S1, then replace the capacitor C100 with a zero ohm jumper or wire. If C100 is used, then wires must be run to a front panel DPDT toggle switch from S1, and from both boards, to be able to disengage the filter.

Load and solder the variable resistors for woofer and tweeter level adjustment. The tick marks are in 0.5 dB gain increments. Center the potentiometers to their 0 dB position before testing the circuit.

Load and solder inductors and diodes. The two LED's can be either mounted on the board or wired to the front panel. The longer lead is the anode A.

Load and solder the capacitors. Start out with the smallest size components and build up in size.

Load and solder the 8 RCA signal connectors and 2 DIN power connectors and any other remaining parts.

5.1 Material List for ORION Crossover/EQ (2 ASP)						LINKWITZ LAB	8/23/08			
						D = www.digikey.com				
						M = www.mouser.com				
Order Qty	Used Qty	Value	Attributes	Mfct-Series	Part No.	\$ each	Order \$ total	Circuit & pcb designation		
10	10	jumper	Zerohm Jumper Wire	YAGEO-MFR	D 0.0QBK-ND	\$0.06	\$0.60	R22, 303, 305, 67,307		
10	6	196	metal film, 1%, 1/4W	YAGEO-MFR	D 196XBK-ND	\$0.11	\$1.08	R43, 56, 64,		
5	4	348	metal film, 1%, 1/4W	YAGEO-MFR	D 348XBK-ND	\$0.11	\$0.54	R309,		
5	4	511	metal film, 1%, 1/4W	YAGEO-MFR	D 511XBK-ND	\$0.11	\$0.54	R52, 308		
5	2	750	metal film, 1%, 1/4W	YAGEO-MFR	D 750XBK-ND	\$0.11	\$0.54	R3		
5	2	1.47k	metal film, 1%, 1/4W	YAGEO-MFR	D 1.47kXBK-ND	\$0.11	\$0.54	R2		
45	44	2.37k	metal film, 1%, 1/4W	YAGEO-MFR	D 2.37kXBK-ND	\$0.11	\$4.86	R6, 5, 27, 28, 214, 215, 216, 217, 218, 219, 29, 35, 36, 37, 38, 39, 40, 42, 44, 45, 46, 47		
5	4	2.61k	metal film, 1%, 1/4W	YAGEO-MFR	D 2.61kXBK-ND	\$0.11	\$0.54	R62, 33		
5	2	2.87k	metal film, 1%, 1/4W	YAGEO-MFR	D 2.87kXBK-ND	\$0.11	\$0.55	R1		
5	2	3.24k	metal film, 1%, 1/4W	YAGEO-MFR	D 3.24kXBK-ND	\$0.11	\$0.54	R55		
5	2	3.48k	metal film, 1%, 1/4W	YAGEO-MFR	D 3.48kXBK-ND	\$0.11	\$0.54	R31		
5	2	4.75k	metal film, 1%, 1/4W	YAGEO-MFR	D 4.75kXBK-ND	\$0.11	\$0.54	R51		
10	6	4.64k	metal film, 1%, 1/4W	YAGEO-MFR	D 4.64kXBK-ND	\$0.11	\$1.08	R30, 41, 65		
10	8	5.11k	metal film, 1%, 1/4W	YAGEO-MFR	D 5.11kXBK-ND	\$0.11	\$1.08	R4, 49, 63, 70		
5	2	7.5k	metal film, 1%, 1/4W	YAGEO-MFR	D 7.50kXBK-ND	\$0.11	\$0.54	R60		
5	4	10k	metal film, 1%, 1/4W	YAGEO-MFR	D 10.0kXBK-ND	\$0.11	\$0.54	R59, 304		
5	2	12.1k	metal film, 1%, 1/4W	YAGEO-MFR	D 12.1kXBK-ND	\$0.11	\$0.54	R302		
10	8	19.6k	metal film, 1%, 1/4W	YAGEO-MFR	D 19.6kXBK-ND	\$0.11	\$1.08	R57, 58, 221, 222		
5	2	21.5k	metal film, 1%, 1/4W	YAGEO-MFR	D 21.5kXBK-ND	\$0.11	\$0.54	R100		
15	14	38.3k	metal film, 1%, 1/4W	YAGEO-MFR	D 38.3kXBK-ND	\$0.11	\$1.62	R54, 208, 209, 210, 211, 212, 213		
5	2	56.2k	metal film, 1%, 1/4W	YAGEO-MFR	D 56.2kXBK-ND	\$0.11	\$0.54	R306		
5	2	68.1k	metal film, 1%, 1/4W	YAGEO-MFR	D 68.1kXBK-ND	\$0.11	\$0.54	R66		
5	2	133k	metal film, 1%, 1/4W	YAGEO-MFR	D 133kXBK-ND	\$0.11	\$0.54	R48		
5	2	147k	metal film, 1%, 1/4W	YAGEO-MFR	D 147kXBK-ND	\$0.11	\$0.54	R53		

61

ORION Construction Kit

Order Qty	Used Qty	Label-Value	Attributes	Mfct-Series	Part No.	\$ each	Order \$ total	Circuit & pcb designation
10	6	100pF	polyester, 10%	Panas-ECQ-P	D P3889-ND	\$0.23	\$2.30	C1, 2, 3
16	16	220pF	polyester, 10%	Panas-ECQ-P	D P3893-ND	\$0.23	\$3.68	C6, 71, 209, 211, 41, 42, 44, 305
2	2	2.7nF	polypropylene, 2%	Panas-ECQ-P	D P3906-ND	\$0.35	\$0.70	C58
2	2	3.3nF	polypropylene, 2%	Panas-ECQ-P	D P3907-ND	\$0.35	\$0.70	C62
2	2	5.6nF	polypropylene, 2%	Panas-ECQ-P	D P3910-ND	\$0.38	\$0.76	C306
4	4	22nF	polypropylene, 2%	Panas-ECQ-P	D P3917-ND	\$0.45	\$1.80	C43, 47
22	22	33nF	polypropylene, 2%	Panas-ECQ-P	D P3919-ND	\$0.47	\$10.34	C35, 36, 48, 49, 50, 51, 52, 53, 54, 55, 63,
2	2	39nF	polypropylene, 2%	Panas-ECQ-P	D P3920-ND	\$0.52	\$1.04	C61
20	20	47nF	polypropylene, 2%	Panas-ECQ-P	D P3921-ND	\$0.60	\$12.00	C101, 66, 65, 204, 205, 206, 207, 212, 213, 214
4	4	82nF	polypropylene, 2%	Panas-ECQ-P	D P3924-ND	\$0.60	\$2.40	C210, 208
6	6	120nF	polypropylene, 2%	Panas-ECQ-P	D P3926-ND	\$1.03	\$6.18	C64, 302, 69
2	2	150nF	polypropylene, 2%	Panas-ECQ-P	D P3927-ND	\$1.03	\$2.06	C100
2	2	330nF	polypropylene, 2%	Panas-ECQ-P	D P3931-ND	\$1.33	\$2.66	C7
50	48	.01uF	metal film	Panas-V	D P4513-ND	\$0.10	\$5.00	C33, 34, 4, 5, 67, 68, 222, 223, 224, 225, 37, 38, 39, 40, 45, 46, 56, 57, 59, 60, 74, 75, 310, 311
2	2	1uF	polyester	Panas-E	D E1105-ND	\$0.86	\$1.72	C78
4	4	10uF	polyester	Panas-ECQ-E(F)	D EF1106-ND	\$4.58	\$18.32	C31, 32
4	4	47uF	electrolytic, 50V	Panas-FC	D P10321-ND	\$0.28	\$1.12	C72, 76
4	4	3300uF	electrolytic, 25V	Panas-FC	D P10288-ND	\$1.97	\$7.88	C29, 30
					not P10287-ND			

20

ORION Construction Kit

Order Qty	Used Qty	Value	Attributes	Mfct-Series	Part No.	\$ each	Order \$ total	Circuit & pcb designation
10	2	LED1	LED, green	Lumex	D 67-1098-ND	\$0.12	\$1.23	D3
4	4	1N5401	diode	Gen. Semicond.	D 1N5401GICT-ND	\$0.43	\$1.72	D1, 2
24	22	OPA2134	opamp	Burr-Brown/TI	D OPA2134PA-ND	\$2.63	\$63.12	U1 - 11
22	22	IC sockets	8 pin tin	Assmann	D AE9986-ND	\$0.08	\$1.76	U1 - 11
8	8	In, T, M, W	phono jack	DGS (tinned)	M 161-4216	\$0.64	\$5.12	J1, 11, 12, 13
0	8		phono jack	DGS (gold plated)	M 161-4217	\$1.08	\$0.00	
0	8		phono jack	CUI Stack (tinned)	D CP-1400-ND	\$0.61	\$0.00	
2	2	CONN	DIN 5 pin	Kobiconn	M 161-0504-E	\$0.78	\$1.56	J9
1	1	S	DPDT	E-Switch	M 612-100-F1111	\$4.17	\$4.17	S1
0	1			E-Switch	D EG2399-ND	\$4.82	\$0.00	
10	4	200uH	EMI bead core	Panas-EMI Bead	D P9817BK-ND	\$0.18	\$1.79	L1, 2
4	4	1k var	trimm pot	Bourns-3362P	D 3362P-1-102LF-ND	\$0.83	\$3.32	R32, 61
1	1		Enclosure, 19 x 8 x 1.75	Hammond	D HM736-ND	\$58.37	\$58.37	
10	10	0.25"	Hex Threaded Standoff	Keystone	D 8714K-ND	\$0.26	\$2.60	
1	1	+/-12V 0.3A	115VAC, regulated, lin. tabletop power supply	Elpac-WM113TT	D EPS131-ND	\$52.00	\$52.00	
0	1	+/-12V 0.5A	90-250VAC switching regulated tabletop supply	Elpac-WRI2731-D5	D EPS106-ND	\$128.00	\$0.00	
							\$298.01	

21

LINKWITZ LAB
 DRION Crossover/Equalizer
 Rev. 221103 orion-2

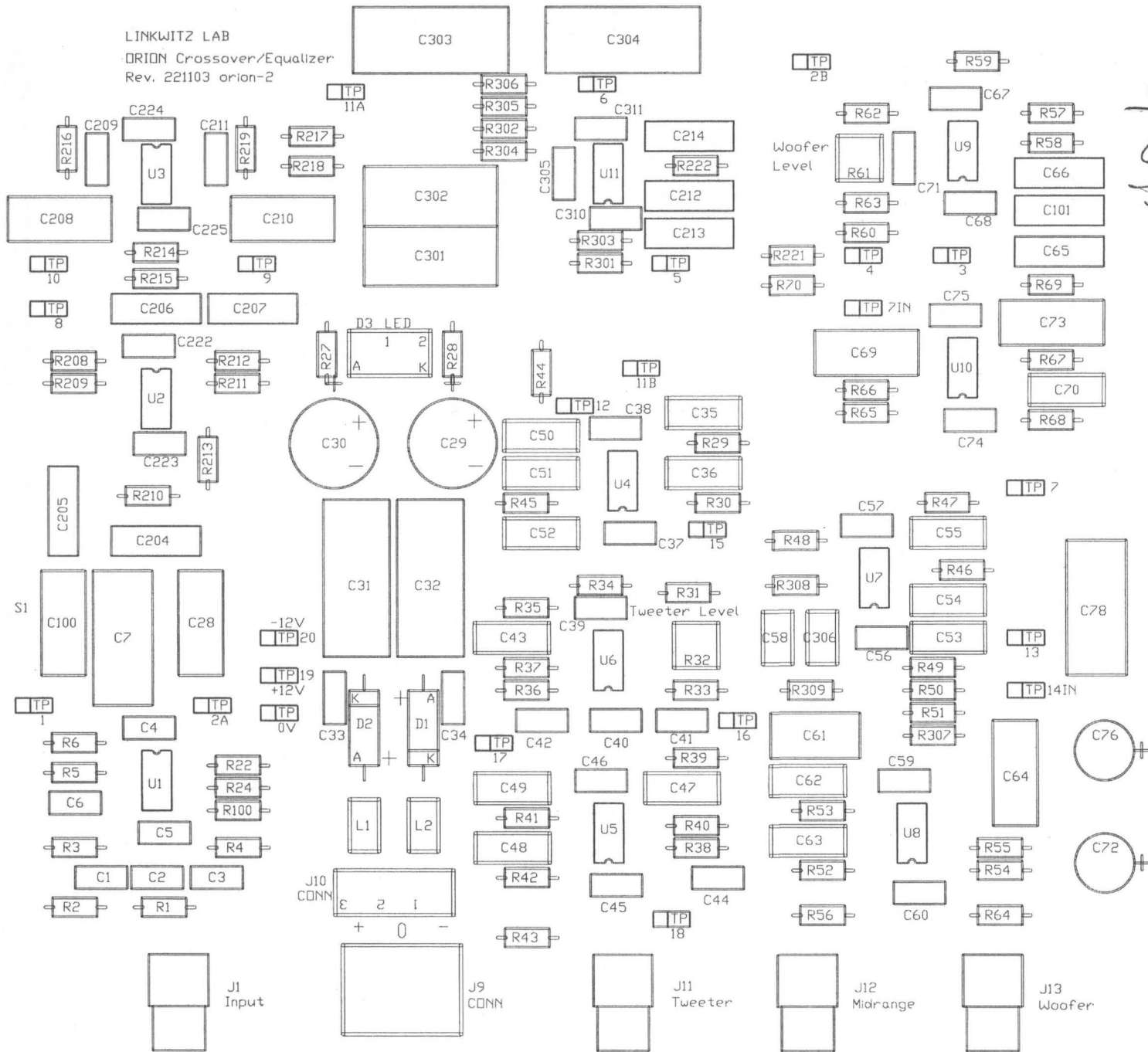

ORION ASP
 Component Designations

1/26/04 CA

6. Circuit Board Interconnections

6.1 ORION circuit side drawing

After the components have been loaded on both circuit boards, separate wires have to be soldered onto the circuit sides that interconnect the DC power inputs. Lay the ORION boards upside down and next to each other with the connectors facing you. See the circuit side drawings.

Run +12V, -12V and Ground wires from one board to the other, so that the external supply can be plugged into either DIN power receptacle. Having two DIN connectors can provide power for a crossover/equalizer should a sub-woofer be added later.

Turn over the two boards, so that the components are up, and place the boards onto a non-conducting surface to test them for correct functioning. It is convenient to mount the boards onto a piece of plywood (17 x 12 x 1/2 inch) with standoffs, using 4-40 metal screws and nuts. This way the board assembly is easy to work with and to transport. Wait with mounting the assembly into any final metal cabinet until it has been fully tested.

One of the LED can be mounted to the front panel as indicator light.

The front panel DPDT switch S1 for defeating the low frequency cut must be wired into both circuit boards at S1. This must be done before testing the boards. Alternatively, a jumper wire may be connected across C100.

LINKWITZ LAB
ORION Crossover/Equalizer

ORION
Circuit side

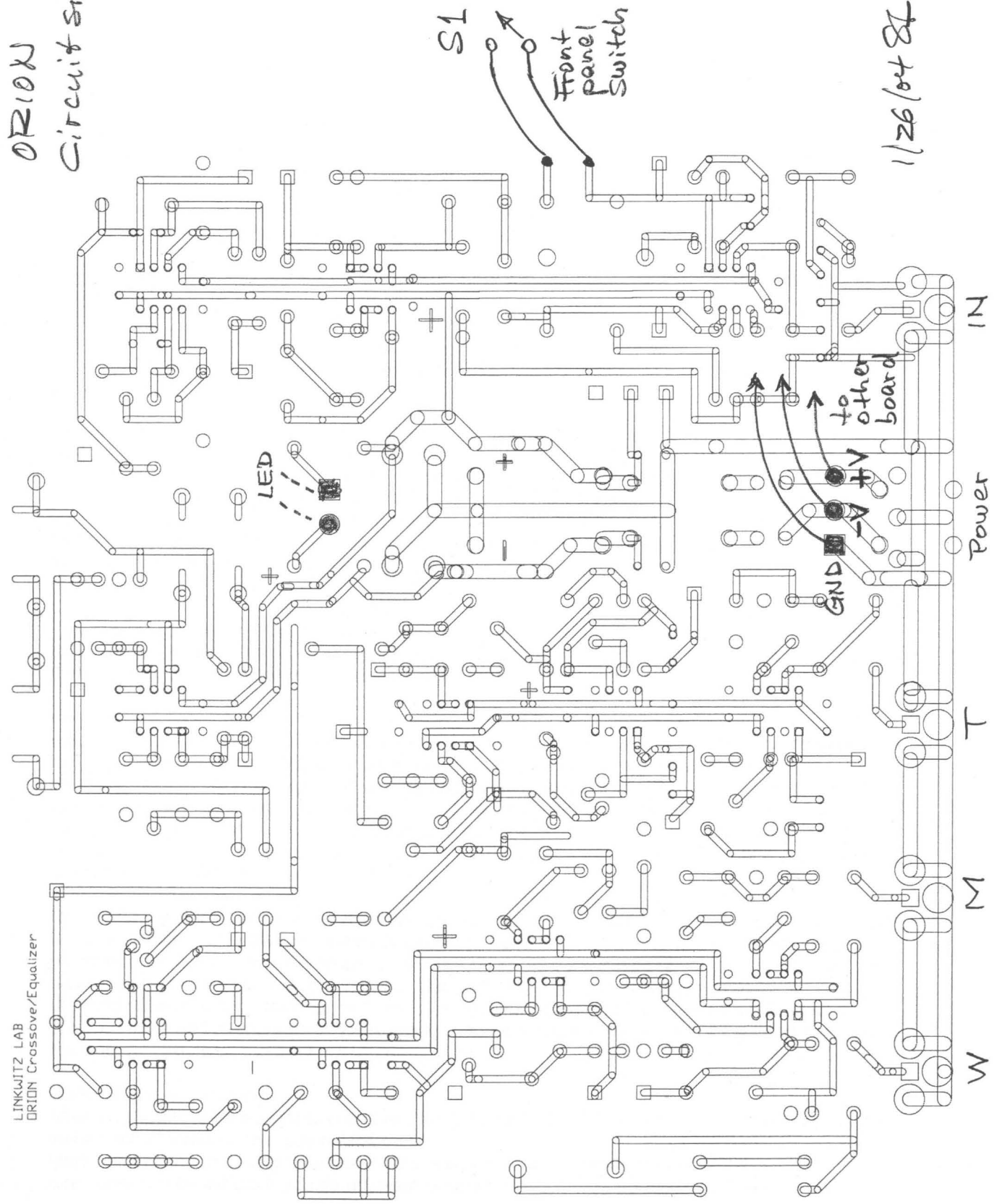

1/26/04 ST

7. Circuit Test

7.1 Transfer function magnitude graph

7.2 Test table

Once the components have been loaded, S1 closed, and the two circuit boards interconnected, then they need to be tested for proper functioning. This must be done prior to connecting the crossover/equalizer to the power amplifiers and speakers.

Insert all the operational amplifier IC's into their sockets. Note that the orientation of the package is not the same in all places.

Plug in the DIN power connector and make sure that the LED's on the two PHOENIX boards light up. If there is a problem check for correct polarity of the LED's and verify the presence of +/-12V on both boards.

Measure the transfer function of the xo/eq and compare it to the graph. If the test equipment for doing this is not available, then use the provided CD for spot checks of the transfer function. Connect the CD player L and R outputs to the corresponding xo/eq inputs. The test signal frequencies on the first two tracks are chosen such that track 1 results in equal amplitude outputs from woofer and midrange channels. Track 2 gives nearly equal amplitude output from midrange and tweeter. These are not the frequencies of the acoustic crossover which also includes the transfer functions of the drivers. The test signals can be measured with a digital voltmeter in ac mode.

The woofer, mid and tweeter output voltages are measured from the hot center pin of the RCA connector to ground. The difference voltages W - M and M - T are measured with the leads of the DVM clipped to the hot center pins of woofer and mid and then mid and tweeter.

Use the Test Table to write down the measured input and output voltages. Divide all measured values by the input voltage to normalize the input to unity. Compare the normalized output values to the given target values. The difference voltages are indicative of the phase shift between channels. If all measured values fall within the allowable range, then the xo/eq can be assumed to work correctly. Otherwise use tracks 3, 4 and 5 to trace the signal flow through the circuit. Table B gives you nominal voltages that should be measured relative to ground. Find the wrong component value or the left out component that causes the problem. After any repair check Test A again for compliance.

The XO/EQ circuit gains have been set with the assumption of identical voltage gains for all power amplifiers. This can be verified by applying the Track 1 signal to each power amplifier and measuring the voltage at the amplifier output terminals. Reduce the input voltage, if necessary, to avoid clipping the amplifier output voltage. The gain of woofer and midrange channel can be changed relative to the midrange, but only by +/-2.5 dB. If greater adjustment range is needed then you must add attenuators to the respective xo/eq outputs. See the ORION support page on the web. Its URL is on the front cover.

XO/EQ Cabinet mounting

After the circuits have been tested and are functioning to specification they can be mounted in the metal cabinet listed on the material list.

Mark and drill the mounting holes for 4-40 metal screws in the bottom cover of the cabinet. The rear panel can be left out if you do not want to punch holes for the connectors. The front panel

ORION Construction Kit

needs holes for the low-cut toggle switch and one LED. The boards must be spaced 0.25 inch from the metal bottom cover to avoid shorting. Use stand-offs or 4-40 nuts. After mounting run Test A again to verify that the XO/EQ is working as expected.

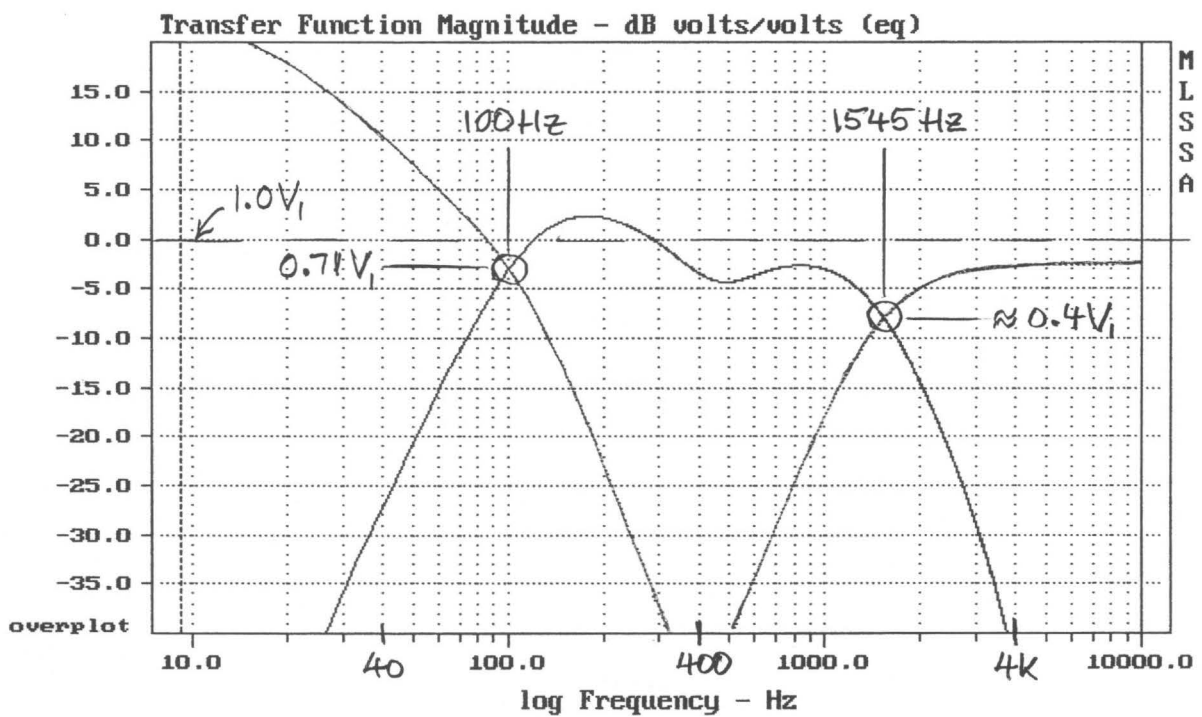

CURSOR: y = -66.1454 x = 10000.5873 (5448)

ORION XO/EQ W & T gain adjustments at midpoint

9-22-102 11:30 AM

MLSSA: Frequency Domain

A - Spot check of xo/eq transfer function magnitude and phase

Use a digital voltmeter (DVM) in AC range. Test signals are on the supplied CD
 Set woofer and midrange gain adjustments to midpoint. The 50HP switch must be closed.

CD track 1

	Input voltage	Woofer out	Mid out	W - M difference	
100 Hz	1.00	0.71 +/- 0.04	0.80 +/- 0.04	0.10 +/- 0.04	
Left channel					Measured
					Divided by measured input voltage

	Input voltage	Woofer out	Mid out	W - M difference	
100 Hz	1.00	0.71 +/- 0.04	0.80 +/- 0.04	0.10 +/- 0.04	
Right channel					Measured
					Divided by measured input voltage

CD track 2

	Input voltage	Mid out	Tweeter out	M - T difference	
1545 Hz	1.00	0.39 +/- 0.02	0.42 +/- 0.02	0.54 +/- 0.03	
Left channel					Measured
					Divided by measured input voltage

	Input voltage	Mid out	Tweeter out	M - T difference	
1545 Hz	1.00	0.39 +/- 0.02	0.42 +/- 0.02	0.54 +/- 0.03	
Right channel					Measured
					Divided by measured input voltage

B - Voltage from resistor to ground for 1 V at left or right input connector.

Verify the continuity of signal flow from test point to test point for each channel.

Test points	Track 3	Track 4	Track 5
	400 Hz Midrange	40 Hz Woofer	4 kHz Tweeter
TP1	0.92		
TP2A, TP2B	0.92		
TP11A, TP11B	0.90		
TP13	0.90		
Mid out	0.66 0.77		
TP2A, TP2B		0.53	
TP4		0.19	
Woofer out		3.40	
TP2A, TP2B			1.00
TP11A, TP11B			0.99
TP15			0.98
Tweeter out			0.75

Rev 3, 2/22/04

8. System Turn-on

8.3 amplifier hook-up

After the speakers have been constructed and tested for correct polarity of the driver connections, and each channel of the crossover/equalizer is functioning according to specification, then it is time for a first complete system check.

Connect the left and right preamplifier outputs to the crossover/equalizer inputs and the woofer, mid and tweeter outputs from the XO/EQ to the designated power amplifier inputs. I use masking tape to put labels on each interconnect cable in order to keep track of the different channels for left and right sides. I also label each speaker cable connector.

All power amplifiers must have identical specifications or equal voltage gains if their power capability is different. Woofer and tweeter XO/EQ channels have limited gain adjustment range and are not be capable of compensating for power amplifier gain differences beyond ± 2.5 dB. Insert the dual banana plugs into the corresponding power amplifier output connectors. The (-) side of each plug should connect to the (-) side of each amplifier output. If a single amplifier is used for the two woofers, then piggy-back their two dual banana plugs.

Go over all interconnections and check for correctness.

Turn on power to the CD player, pre-amplifier, XO/EQ. Turn on power to the amplifiers.

8.1 Pink noise tests

Track 6 of the Test CD has pink noise that alters back and forth between left and right channels. It is used to compare the two speakers acoustically. Place the two speakers within 1 inch next to each other and with as much open area around them as possible. The two speakers should sound closely similar. Pink noise is a very revealing test signal and it is almost impossible not to note slight differences, but anything pronounced would indicate a problem somewhere in the system and needs to be corrected.

Be careful not to set the volume level too high, because the very low frequency content of the noise can push the woofer drivers very hard. This is a good time to check out the effectiveness of the low frequency cut switch, by observing how the woofer excursions are reduced when it is activated.

Track 7 of the Test CD carries identical pink noise in left and right channels. It is used to test for a well defined center image after the speakers have been moved to their intended position in the room and you listen from the "sweet spot". The speakers need breathing room around them, the more the better. The tweeter should be at least 2 feet from the side wall and more than 4 feet from the rear wall. The speakers perform best when listened to close up. For a 10 foot separation sit at 9 feet in front of them, with 8 feet between them sit at 7 feet. The speakers are aiming at a point on the wall behind you. The close listening position will present you with a large and deep sound stage with precisely defined phantom images. You lose some of this due to room reverberation when you sit further away, but the large and open source of sound remains.

8.2 Rattle and buzz test

A last test is to check for rattle and buzz in the speakers and your room. Considerable mechanical energy is transmitted from the woofer and midrange drivers into the cabinet and it can easily excite large amplitude vibration which causes rattle or buzz when any moving parts or objects hit their stops.

The supplied test CD has 3 tracks with 100% amplitude modulated signal bursts which are very effective for finding vibration problems. It is important to start playing them at low volume first. Then slowly increase the volume to hear if there are any rattles. At very high volumes you will hear the clipping of the power amplifier, though it may not seem that loud. There is a good chance that various objects in your room will also rattle. If necessary tighten woofer, midrange or tweeter mounting screws or whatever needs tightening.

Do not attach spikes or casters to the bottom of the Orion. If you suspect that structure borne vibration energy is transmitted into the floor and reradiated, then place heavy felt mats (1/2 inch thick) under the speakers. This has a vibration damping effect unlike spikes or casters.

Caution, should you run the test tracks without using the crossover/equalizer directly through the power amplifiers into the drivers, then to avoid damage to the drivers use

Tracks 8 and 9 only for the 10" woofers,

Track 10 only for the 8" midrange.

Finally !

After the system has passed all tests, put on your favorite music, sit back and listen. You may experience a short break-in period, but I believe it is more the listener than the speaker that needs it.

Congratulations, you are done, enjoy !

ORION System hook-up from Preamplifier to Crossover/Equalizer to Power Amplifier to Speaker Cable

